

BB02-YF

CUSTOMER PRODUCT SPECIFICATION SHEET



BB02-YF:- 1.00mm x 1.00mm (0.039" x 0.039") PIN HEADER, DUAL ROW, STRAIGHT, SMT TYPE, 04 TO 80 CONTACTS

SPECIFICATIONS

CURRENT RATING: 1AMP
 INSULATOR RESISTANCE: 500 MEGOHMS MIN.
 DIELECTRIC WITHSTANDING: AC 300 V
 CONTACT RESISTANCE: 20m OHMS MAX.
 OPERATING TEMPERATURE: -40°C TO +105°C
 CONTACT MATERIAL: PHOSPHOR BRONZE
 INSULATOR MATERIAL: THERMOPLASTIC, UL 94V-0
 STANDARD:LCP
 PLATING: GOLD OR TIN OVER 30-50U" NICKEL
 SOLDERABILITY IR REFLOW: 280°C FOR 10 SEC
 MANUAL SOLDER: 380°C FOR 3-5 SEC

MATES WITH: - BB02-WA

NOTES:

1. PARTS WITH SMALL PIN NUMBERS MAY BE PACKED IN BOX INSTEAD OF TUBE.

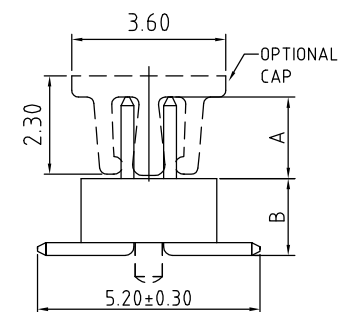
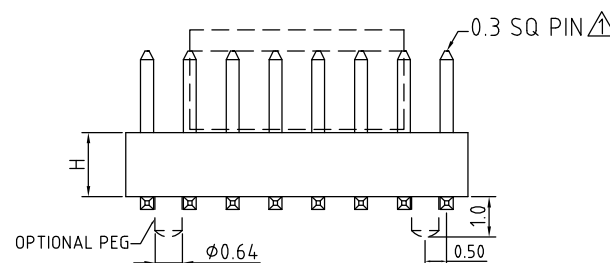
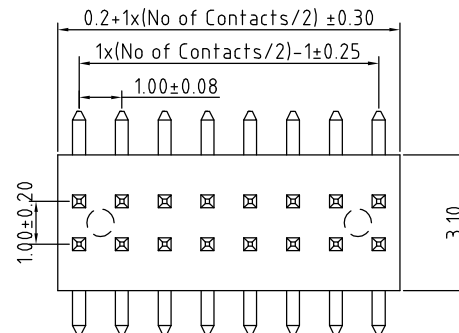

HOW TO ORDER

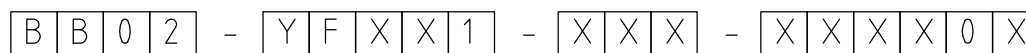

NO. OF CONTACTS:
 04 to 80
 (MIN. PIN# 06 FOR W/PEG VERSION.)

CONTACT PLATING OPTIONS:
 K = GOLD FLASH (STANDARD)
 P = 10U" GOLD OVERALL
 Q = 15U" GOLD OVERALL
 R = 30U" GOLD OVERALL
 T = BRIGHT TIN
 M = MATT TIN

LOCATING PEG OPTIONS:
 A = WITH PEG
 B = WITHOUT PEG

PACKAGING OPTIONS:
 3 = TUBE
 5 = TUBE + CAP
 6 = TAPE & REEL
 8 = TAPE & REEL + CAP
 (SEE NOTE 1)

PIN LENGTH A (1/10mm)
 PLEASE SPECIFY PIN LENGTH REQUIRED
 I.E. 2.5mm = 25
 TOL. ±0.25mm

INSULATOR HEIGHT 'H'
 0: H = 1.5mm
 1: H = 1.0mm
 STANDARD = 0

PIN LENGTH B (1/10mm)
 PLEASE SPECIFY PIN LENGTH REQUIRED
 I.E. 2.5mm = 25
 TOL. ±0.25mm
 MIN. B = 1.9mm if H = 1.5mm
 MIN. B = 1.4mm if H = 1.0mm

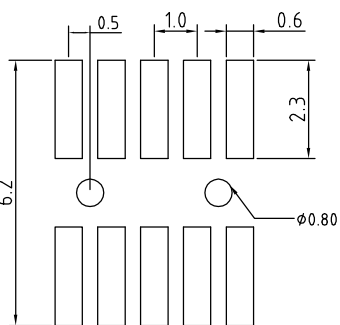

RECOMMENDED PCB SMT LAYOUT

REV.	DATE & DRN
10	26/04/05-NYW RELEASE
11	12/07/05-NYW OPTION
12	08/08/05-CYC AMEND PIN DIMENSION
13	12/02/06-NYW DRAWING MODIFICATION
14	17/11/07-CYC AMEND MIN. PIN# TO 04
15	09/04/08-NYW AMEND INSULATOR OPTION
16	23/07/08-NYW PLATING MODIFICATION
17	11/08/08-CYC CHANGE PLATING OPTIONS
18	26/11/08-CYC ADD MIN. DIMENSION OF "B"
19	24/02/08-NYW DRAWING MODIFICATION
20	08/04/08-NYW DRAWING MODIFICATION
21	25/02/16-NYW AMEND PIN MATERIAL

Scale: 8:1	THIRD ANGLE	Unstated Tolerances: X ± 0.30 X ± 0.25 XX ± 0.15 .XXX ± 0.10
Drawn: NYW		
App'd: XXX	Title: PIN HEADER	Material: SEE NOTE
Date: 25 FEB. '16	Revision: 2.1	NOT TO SCALE
		Unit: mm

THIS DRAWING IS CONFIDENTIAL AND MUST NOT BE COPIED OR DISCLOSED WITHOUT WRITTEN CONSENT

Type BB02-YF
BB02-YF
Drawing Number:
Sheet 1 of 1
Drawing © E and O E